Engine Timing Tool Kit For PSA 1.0/1.2VTi Engines



Information

- Designed for working on the camshaft drive, renewing the cylinder head gasket, etc.
 - Includes:
 - Camshaft adjustment tool to be used as OEM 0109-2a.
 - Flywheel locking tool to be used as OEM 0109-2b.
- Suitable for the following models with 1.0/1.2vti engines:
Peugeot 208 / 2008 (2012-'14), Citroen C3.
Engines Codes: EBO (ZMZ), EB2 (HMZ).

Precautions

- Always wear safety gear.
- Working in a clean and safe environment.
- This task should be carried out by trained personnel.
- Make sure to consult manufacturers manual.
- Do NOT use with air tools.

Information



1

	Description	OEM
1, 2, 3, 4, 5	Camshaft Timing Assembly	0109-2A, EN-52127-1
6	Crankshaft Timing Pin	0109-2B, EN-52127-2



2



4



3



5



6

Applications

Make	Model	Year	Engine Codes	EB2M [HMY]	LES/D12XHT [HNS/EB2ADTS]
Citroen	Berlingo III	2014-on	1.0	HMP [EB2FB]	[HNS/EB2ADTS]
	C1 II	2014-2018	EBO [ZMZ]	HMR [EB2FA]	LES/EB2ADT
	C3	2012-on	EBOF [ZMZ]	HMT [EB2]	LES/EB2DT
	C4	2014-2019	ZMZ [EBO]	HMT [EB2F]	LEZ/EB2F
	C-Elysee	2012-on	ZMZ [EBOF]	HMU [EB2D]	LEZ/EB2FA
	C4 Picasso/Grand Picasso II	2015-2018	1.2	HMU [EB2FD]	
	C4 SpaceTourer/Gran Space Tourer	2018-on	[EB2ADT]	HMV [EB2M]	
	C5 Aircross	2019-on	[EB2ADTS]	HMY [EB2M]	
	DS3/DS3 Cabrio	2013-2015	[EB2FAD]	HMZ [EB2]	
	DS4	2014-2015	/EB2FA	HMZ [EB2F]	
DS	3		1PP [HM01]	HNP [EB2ADT]	
	3 Crossback		EB2 [HMT]	HNS [EB2ADTS]	
	4/4 Crossback		EB2 [HMW]	HNV [EB2DT]	
	7 Crossback		EB2 [HMZ]	HNV [EB2DTM]	
Vauxhall/ Opel	Combo-E	2018-on	EB2ADT [HNP]	HNW [EB2DTSM]	
	Corsa-F	2019-on	EB2ADTD	HNX [EB2DT]	
	Crossland X	2017-on	EB2ADTS	HNX [EB2DTSD]	
	Grandland X	2017-on	EB2ADTS [HNS]	HNY [EB2DTS]	
Peugeot	108	2014-2018	EB2DT [HNZ]	HNZ [EB2DT]	
	208	2012-2019	EB2DTS [HNY]	LEG/EB2ADTS	
	301	2012-on	EB2F [HMT]	LEG/EB2DTS	
	308	2013-on	EB2F [HMX]	LES/B12XHT [EB2DTS]	
	2008	2013-2020	EB2F [HMZ]		
	3008	2016-2018	EB2FA [HMR]	LES/D12XHL [HNP/EB2ADT]	
	5008	2014-on	EB2FAD		
Toyota	Aygo	2015-2018	EB2FB [HMP]	LES/D12XHT [EB2ADTS]	
			EB2M [HMV]		

Instructions

- Assemble the camshaft timing tool combining parts 1, 2, 3, 4, and 6.
- Fit the timing tool on the camshafts.

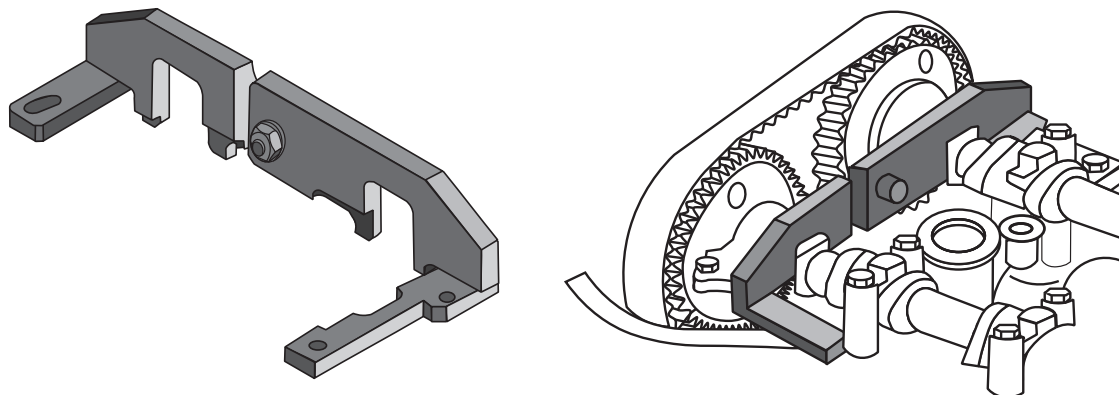

- Insert the crankshaft timing pin (part 5) into the flywheel.

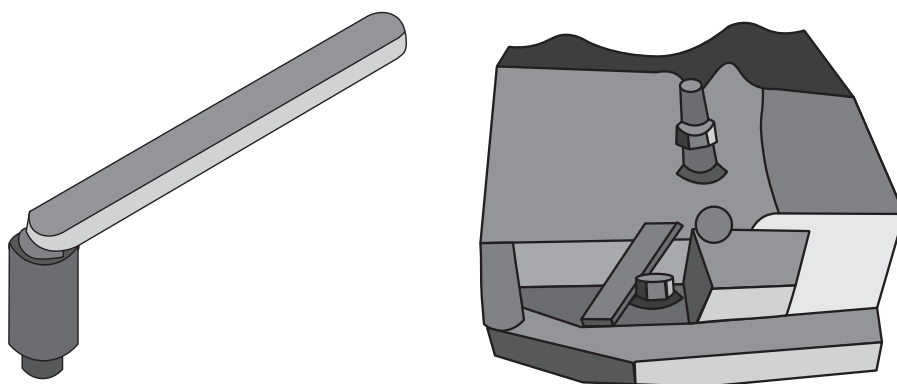

Safety Precautions

- Damage to the engine will occur if the timing belt has been damaged if the engine is an interference engine. Before the cylinder heads are removed a compression check of all cylinders should be made.
- When the timing belt/chain has been removed, do not turn the crankshaft or camshaft.
- Remove the spark plugs/glow plugs or injectors to make turning the engine easier.
- Check all tightening torques.
- Don't turn the engine using the camshaft or any other sprocket.
- Disconnect the battery earth lead (check Radio code is available).
- Don't use cleaning fluids on belts, sprockets or rollers.
- Some toothed timing belts are not interchangeable. Check the replacement belt has the correct tooth profile.
- Always mark the belt with the direction of running before removal.
- Don't lever or force the belt onto its sprockets.
- Don't use timing pins to lock the engine when slackening or tightening the crankshaft pulley bolts.

Warranty

If you are unsure on how to use the item please contact us. If it were to fail due to a manufacturing fault or poor workmanship we will repair or replace it. Please contact your local dealer in the event you need to send the item back. You can also make a repair/replacement request on our website and download & complete the form online. Normal wear and tear along with misuse will void any warranty. Consumables are not covered under warranty.

www.welzh.com

Limited **12 month** warranty



Welzh Werkzeug Ltd.
Loanwath Road
Gretna, Scotland
DG16 5HD
+44 (0)1461 700120